

PRODUCT DATASHEET

Digital MEMS Microphone

IM2718B261-NC4

Contents

1. Introduction	3
1.1. Overview.....	3
1.2. Product Features.....	3
1.3. Typical Application.....	3
2. Absolute Maximum Ratings.....	4
3. Acoustic and Electrical Characteristics	4-6
4. Frequency Response Curve.....	6
5. Test Setup Drawing.....	7
6. Timing Diagram.....	7
7. Mechanical Specifications.....	8
8. Recommended Interface Circuit	9
9. Vacuum nozzle pickup location.....	9
10. Example solder stencil pattern.....	9
11. Recommended Reflow Profile.....	10
12. Packaging Specifications.....	11-13
12.1. Tape Specification.....	11
12.2. Reel Dimension.....	11
12.3. The Content of Box(13" reel)	12
13. Reliability Specifications.....	13
14. Version History.....	14

1. Introduction

1.1 Overview

IM2718B261-NC4 is an omnidirectional, Bottom - ported, PDM digital output MEMS microphone. It has high performance and reliability.

Other high-performance specifications include 120 dB SPL acoustic overload point in high performance mode, ± 1 dB sensitivity tolerance and enhanced immunity to both radiated and conducted RF interface.

Excellent acoustic performance, along with the compact size(2.75*1.85*0.95mm) is best-suited for a wide range of consumer electronic products, offering a product with high-quality to meet the application requirement.

1.2 Product Features

- PDM Output
- Small Size
- High SNR
- RF Protection
- RoHS/Halogen free compliant
- Standard SMD Reflow

1.3 Typical Application

- Microphone Arrays
- Tablets
- Digital Still Cameras
- Headsets
- Notebook PCs
- Smart home devices, Internet of Things

2. Absolute Maximum Ratings

Parameter	Absolute Maximum Rating	Units
Voltage Range of VDD to Ground	-0.5 to +4.0	V
DATA, CLOCK, L/R to Ground	-0.5 to +4.0	V
Input Current	±5	mA
Temperature Range	-40 to +100	°C

Stresses exceeding these “Absolute Maximum Ratings” could cause permanent damage to the microphone. These are stress rating only. Functional operation at these or any other conditions beyond those indicated under “Absolute and Electrical Characteristics” is not implied. Exposure beyond those indicated under “Acoustic and Electrical Characteristics” for extended periods may affect microphone reliability.

3. Acoustic and Electrical Characteristics

(Test Conditions: 23±2°C, 55±20% R.H. VDD=1.8V, F_{clock}=2.4MHz, L/R pin grounded, no load, unless otherwise indicate)

General Microphone Specifications

Parameter	Symbol	Conditions	Min	Typ	Max	Unit
Supply Voltage	V _{DD}	-	1.65	-	3.6	V
Clock Frequency Range	Sleep Mode	-	0	-	10	KHz
	Low-Power Mode	-	150	-	900	KHz
	Normal Mode	-	1.3	-	4.8	MHz
Sleep Current	ISLEEP	F _{CLOCK} < 10 kHz	-	3	-	μA
DC Output		Fullscale = ±100	-	4	-	% FS
Polarity		Input higher voltage	Increasing density of 1's			
Directivity	D(θ)	Omni-Directional				
Data Format	-	½ Cycle PDM				
Short Circuit Current	ISC	Connect DATA to Ground	1	-	20	mA
Output Load	C _{LOAD}	-	-	-	100	pF
Fall-asleep Time		F _{CLOCK} < 10kHz	-	-	20	us
Wake-up Time		F _{CLOCK} > 150kHz	-	-	20	ms
Startup Time	T _{start}	Time to start up in any mode after VDD and CLOCK applied.	-	-	20	ms
Mode Switch Time	-	Time to switch between modes. VDD remains on	-	-	20	ms

Normal Mode

(Test Conditions: $V_{DD}=1.8V, F_{clock}=2.4MHz$, unless otherwise indicate)

Parameter	Symbol	Conditions	Min	Typ	Max	Unit
Sensitivity	S	94dB SPL @1KHz	-27	-26	-25	dBFS
Current Consumption	I_{DD}	-	-	680	-	μA
S/N Ratio	S/N	94dB SPL @1KHz (A-weighted)	-	64	-	dB
Total Harmonic Distortion	THD	94dB SPL @1KHz	-	0.2	-	%
Acoustic Overload Point	AOP	10% THD @ 1 kHz	-	120	-	dB SPL
Power Supply Rejection	PSR	100 mVpp square wave @ 217 Hz, A-weighted	-	-80	-	dBFS

Low-Power Mode

(Test Conditions: $V_{DD}=1.8V, F_{clock}=768KHz$, unless otherwise indicate)

Parameter	Symbol	Conditions	Min	Typ	Max	Unit
Sensitivity	S	94dB SPL @1KHz	-27	-26	-25	dBFS
Current Consumption	I_{DD}	-	-	280	-	μA
S/N Ratio	S/N	94dB SPL @1KHz (A-weighted)	-	63	-	dB
Total Harmonic Distortion	THD	94dB SPL @1KHz	-	0.2	-	%
Acoustic Overload Point	AOP	10% THD @ 1 kHz	-	120	-	dB SPL
Power Supply Rejection	PSR	100 mVpp square wave @ 217 Hz, A-weighted	-	-90	-	dBFS

Microphone Interface Specifications

Parameter	Symbol	Conditions	Min	Typ	Max	Unit
Clock Duty Cycle	F_{DC}	-	40	-	60	%
Logic Input High	V_{IH}		$0.65 \times V_{DD}$	-	$V_{DD}+0.3$	V
Logic Input Low	V_{IL}		-0.3	-	$0.35 \times V_{DD}$	V
Logic Output High	V_{OH}		$V_{DD}-0.45$	-	-	V
Logic Output Low	V_{OL}		-	-	0.45	V

MICROPHONE STATE DIAGRAM

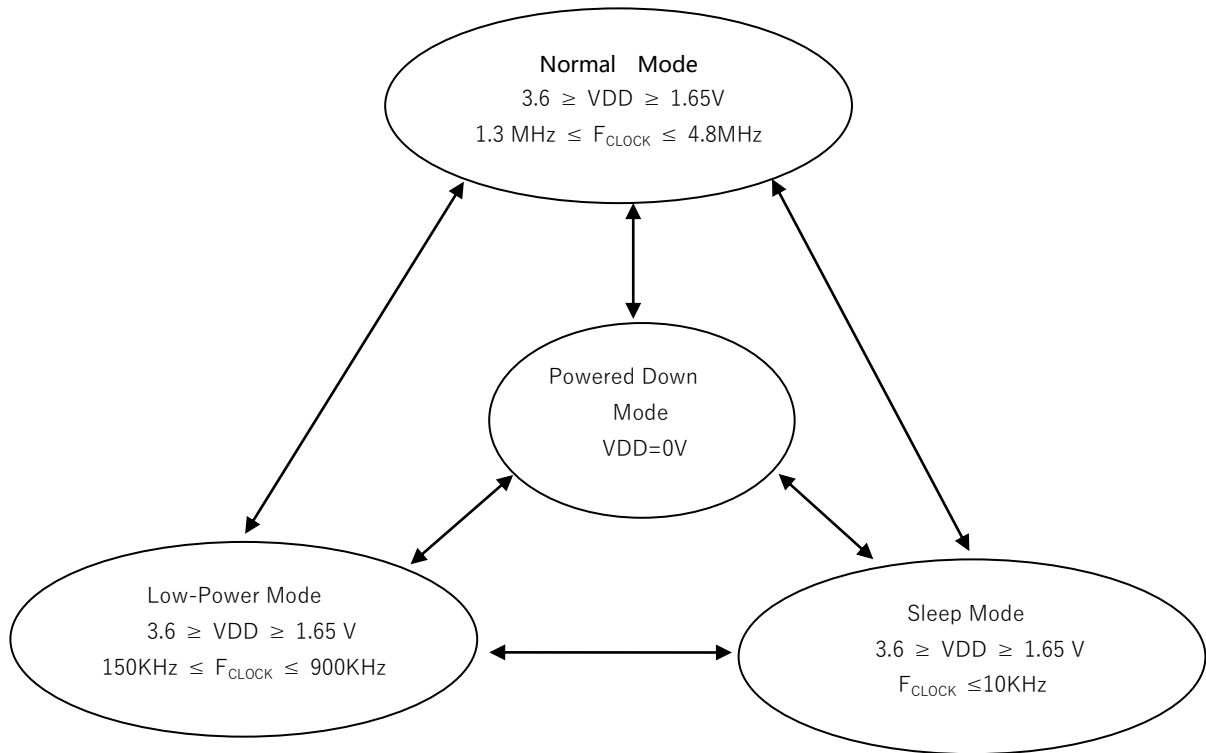

4. Frequency Response Curve

Frequency Response (0dB=1V/Pa)

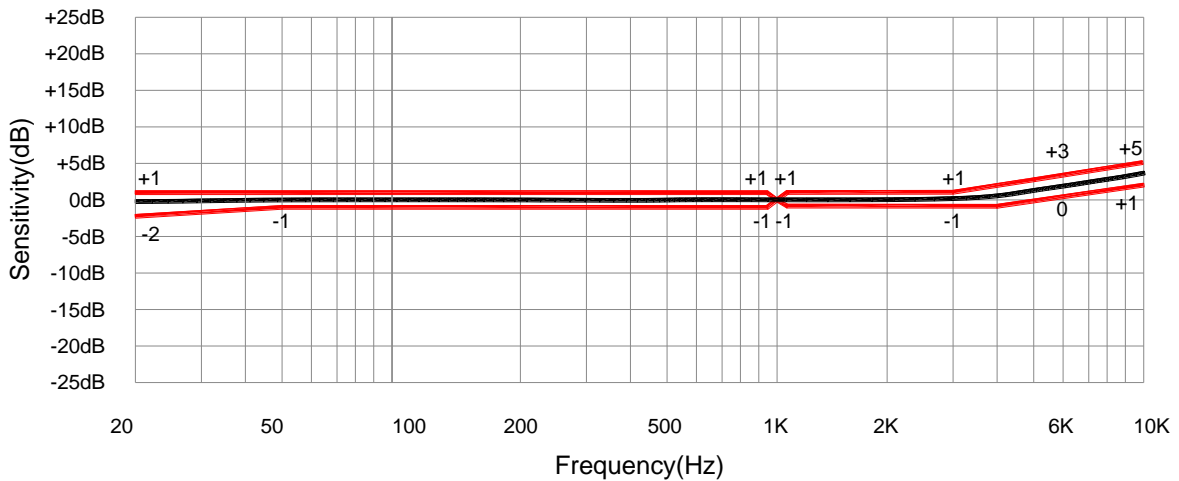

5. Test Setup Drawing

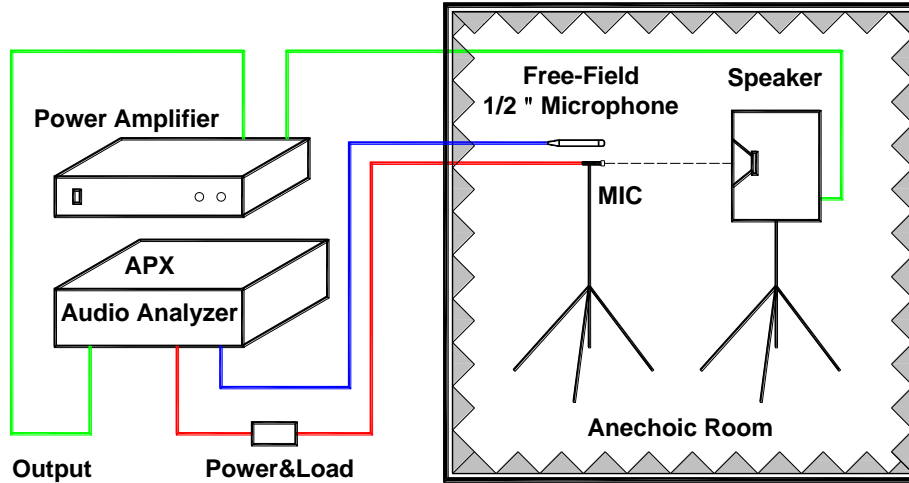

6. Timing Diagram

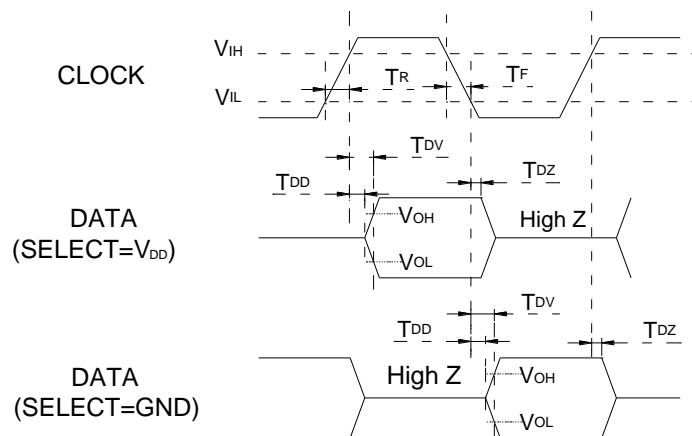

Parameter	Symbol	Min	Typ	Max	Unit
Clock Rise / Fall Time	T_R / T_F	-	-	15	ns
DATA into Hi Z time	t_{DZ}	5	-	20	ns
Delay Time For Data Driven	t_{DD}	25	-	50	ns
DATA Valid time	t_{DV}	40	-	100	ns

Microphone	Select (L/R)	Asserts DATA On	Latch DATA On
Mic(High)	V_{DD}	Rising clock edge	Falling clock edge
Mic(Low)	GND	Falling clock edge	Rising clock edge

7. Mechanical Specifications

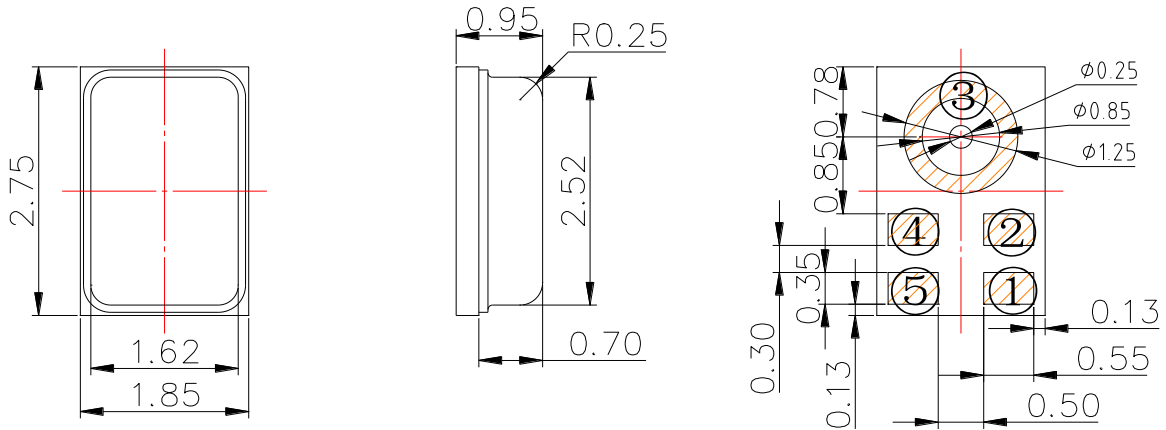

Item	Dimension	Tolerance	Units
Length(L)	2.75	±0.10	mm
Width(W)	1.85	±0.10	mm
Height(H)	0.95	±0.10	mm
Acoustic port(AP)	Φ0.25	±0.10	mm

Pin Output	
Pin#	Function
1	VDD
2	CLOCK
3	GND
4	L/R
5	DATA

Note:

All dimensions are in millimeter(mm).

Tolerance: +/-0.1mm unless otherwise specified.

8. Recommended interface circuit & timing diagram

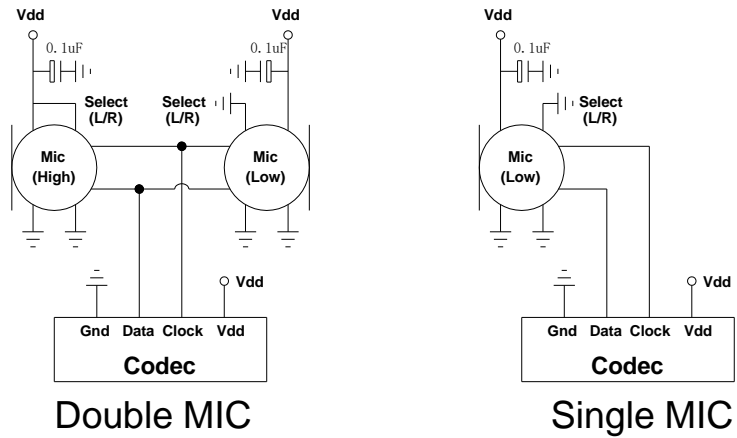

9. Vacuum nozzle pickup location

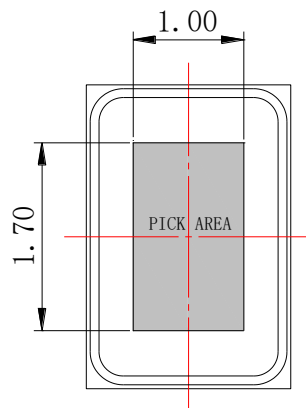

10. Example solder stencil pattern

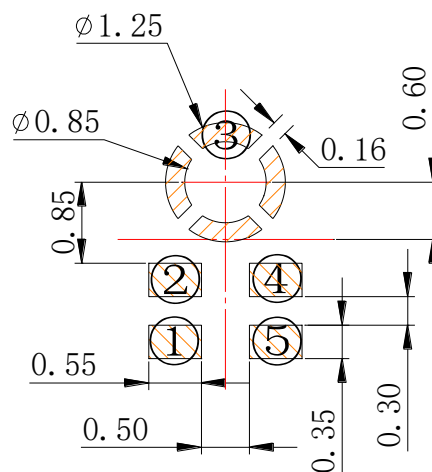

11. Recommended Reflow Profile

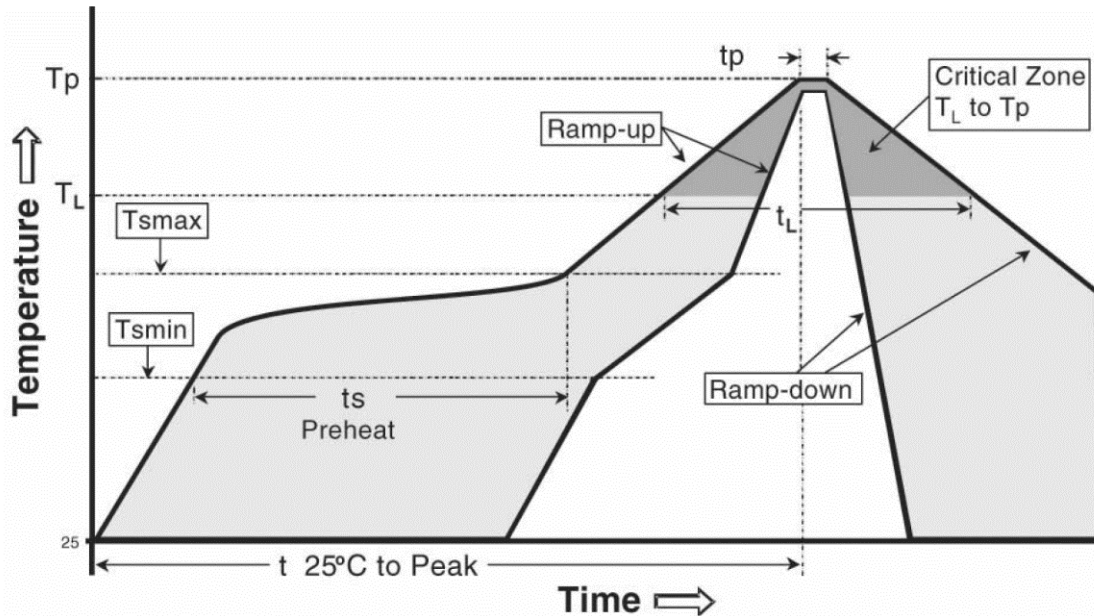

Profile Feature	Pb-Free
Average Ramp-up rate (T_{smax} to T_P)	3°C/second max.
Preheat Temperature Min (T_{smin}) Temperature Max (T_{smax}) Time (T_{SMIN} to T_{SMAX}) (t_s)	150°C 200°C 60-180 seconds
Time maintained above: Temperature (T_L) Time (t_L)	217°C 60-150 seconds
Peak Temperature (T_P)	260°C
Time within 5°C of actual Peak Temperature (t_p)	20-40 seconds
Ramp-down rate(T_P to T_{smax})	6°C/second max
Time 25°C to Peak Temperature	8 minutes max

Notes:

1. Pulling vacuum over acoustical hole of the microphone is not allowed, because the device can be damaged by vacuum.
2. Wash the board after reflow process is not allowed, because board washing and cleaning agents can damage the device. Device should not be exposed to ultrasonic processing or cleaning.
3. Recommended number of reflow is no more than 3 times.

12. Packaging Specifications

11.1. Tape Specification

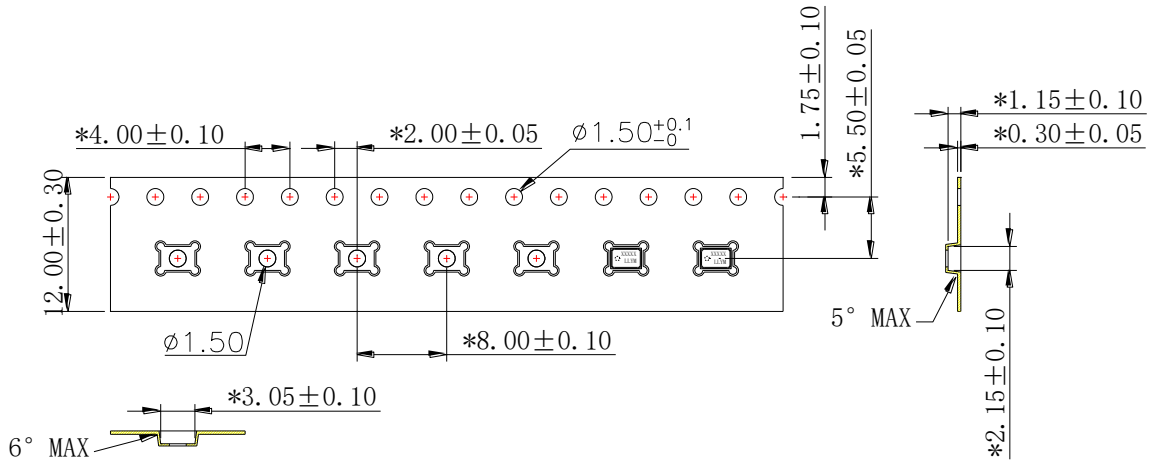

Line	Character	Description
1	XXXXXX	Unique Trace Code
2	LL	Identify Code
3	Y	Year
4	M	Month

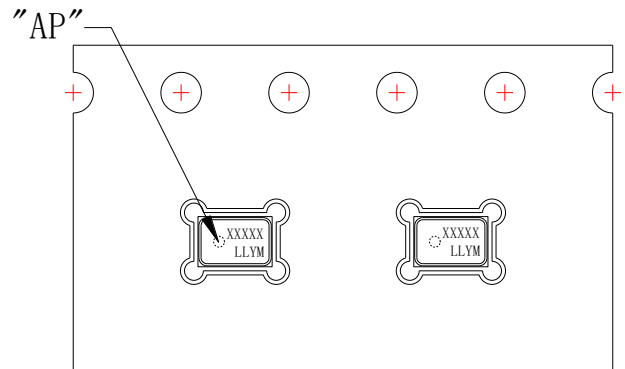

11.2. Reel Dimension

13" reel dimensions (unit:mm)

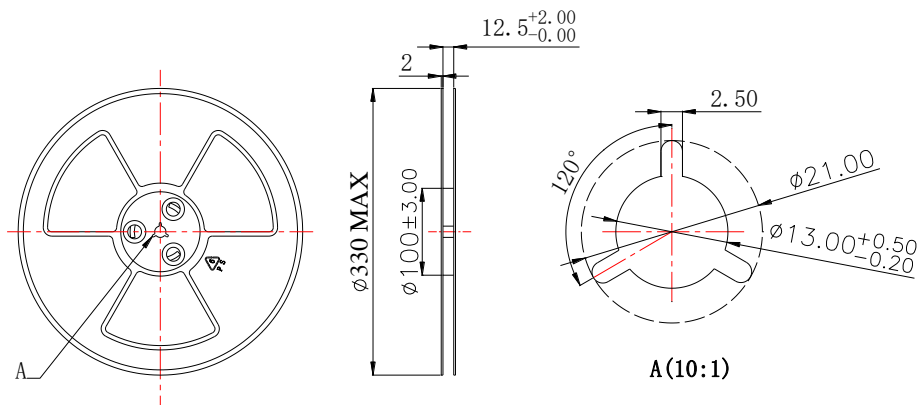

11.3. The Content of Box(13" reel)

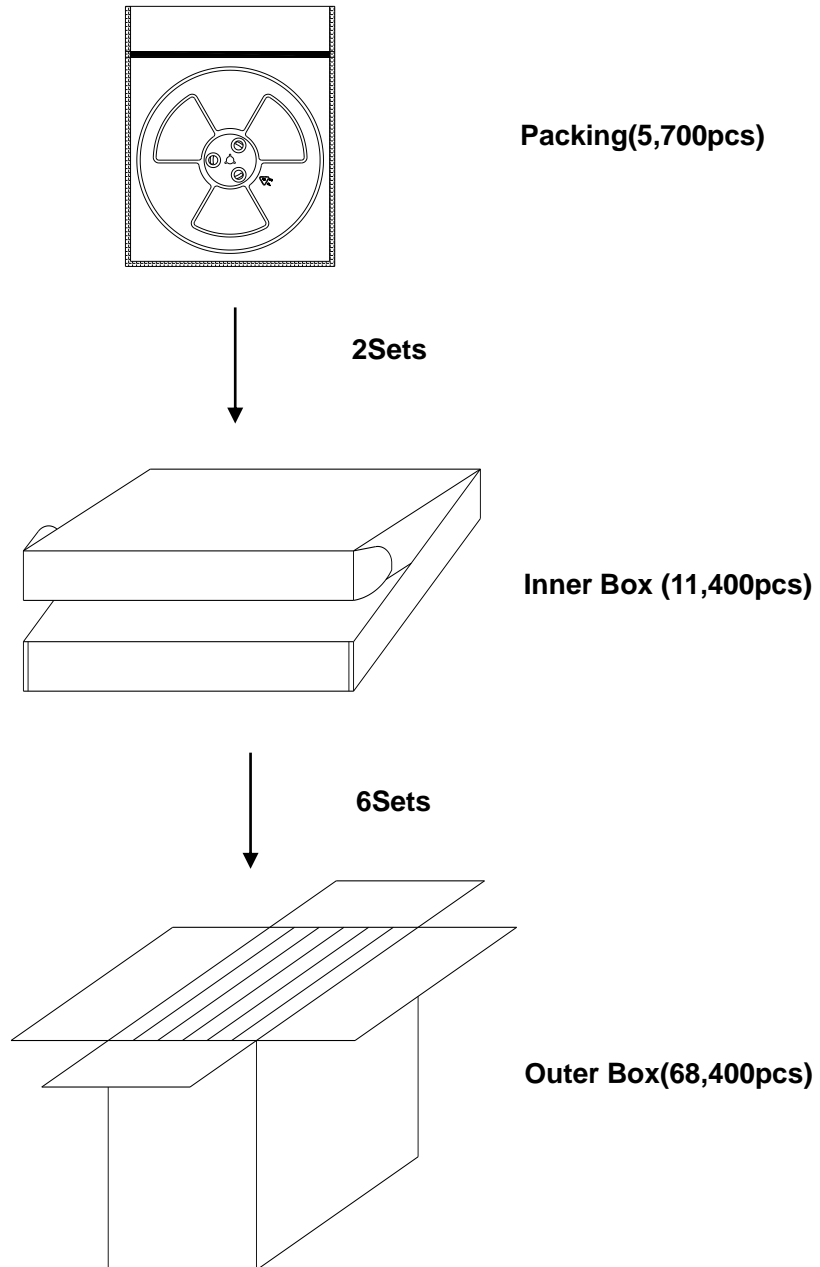

Qty/ Reel	Qty/ One Inner Box	Qty/ Outer Box (Six Inner Box)
5,700 pcs	11,400 pcs	68,400 pcs
Φ 330mm	355 × 340 × 45mm	365 × 290 × 370mm

13. Reliability Specifications

Test Item	Detail
Thermal Shock	100 cycles of air-air thermal shock from -40°C to +105°C with 15 minute soaks.
High Temperature Storage	+105°C environment for 500 hours.
Low Temperature Storage	-40°C environment for 500 hours.
High Temperature Test	+105°C environment while under bias for 500 hours.
Low Temperature Test	-40°C environment while under bias for 500 hours.
Humidity Test	+85°C/85% R.H. environment while under bias for 500 hours.
Vibration Test	16 minutes in each X, Y, Z axis from 20 to 2,000 Hz with peak acceleration of 20G.
Drop Test	1.5-meter height onto a concrete surface each time at three directions in state of packaging.
Reflow Test	5 reflow cycles with peak temperature of +260°C.
ESD Test	Under C=150pF, R=330ohm. Tested to ±8KV contact to the case and tested to ±2kV contact to I/O terminals. 10 times. Grounding.

Note: The microphone sensitivity after stress must deviate by no more than ±3dB from the initial value.

