

PRODUCT DATASHEET

Analog MEMS Microphone

For Active Noise Cancellation

IM3526B381-N314H

Contents

1. Introduction	3
1.1. Overview.....	3
1.2. Product Features.....	3
1.3. Typical Application.....	3
2. Absolute Maximum Ratings.....	4
3. Acoustic and Electrical Characteristics	4
4. Frequency Response Curve.....	5
5. Test Setup Drawing.....	5
6. Mechanical Specifications.....	6
7. Recommended Interface Circuit	7
8. Vacuum nozzle pickup location.....	7
9. Example solder stencil pattern.....	7
10. Recommended Reflow Profile.....	8
11. Packaging Specifications.....	9-10
11.1. Tape Specification.....	9
11.2. Reel Dimension.....	9
11.3. The Content of Box(13" reel)	10
12. Reliability Specifications.....	11
13. Version History.....	12

1. Introduction

1.1 Overview

IM3526B381-N314H is an analog bottom port MEMS microphone with high performance and reliability. The IM3526B381-N314H integrates a MEMS microphone element, an impedance converter, and an output amplifier.

Other high-performance specifications include 128 dB SPL acoustic overload point in high performance mode, ± 1 dB sensitivity tolerance and enhanced immunity to both radiated and conducted RF interface.

Excellent acoustic performance, along with the compact size(3.50*2.65*0.98mm) is best-suited for a wide range of consumer electronic products, offering a product with high-quality to meet the application requirement.

1.2 Product Features

- Omnidirectional
- High SNR
- RF Protection
- HD Voice MEMS Microphone
- RoHS/Halogen free compliant
- Standard SMD Reflow

1.3 Typical Application

- Smartphones
- Microphone Arrays
- Tablets
- Cameras
- Headsets
- Notebook PCs
- Smart home devices, Internet of Things

2. Absolute Maximum Ratings

Parameter	Absolute Maximum Rating	Units
Voltage Range of VDD to Ground	-0.3 to +3.9	V
Voltage Range of Output to Ground	-0.3 to +3.9	V
Input Current to Any Pin	±5	mA
Temperature Range	-40 to +100	°C

Stresses exceeding these “Absolute Maximum Ratings” could cause permanent damage to the microphone. These are stress rating only. Functional operation at these or any other conditions beyond those indicated under “Absolute and Electrical Characteristics” is not implied. Exposure beyond those indicated under “Acoustic and Electrical Characteristics” for extended periods may affect microphone reliability.

3. Acoustic and Electrical Characteristics

(Test Conditions: 23±2°C, 55±20% R.H)

Parameter	Symbol	Conditions	Min	Typ	Max	Unit
Directivity	D(θ)	Omni-Directional				
Sensitivity	S	94dB SPL @1KHz	-39	-38	-37	dBV/Pa
Supply Voltage	V _{DD}		1.6	2.0	3.6	V
Current Consumption	I _{DSS}	V _{DD} =2.0V			250	μA
S/N Ratio	S/N	94dB SPL @1KHz (A-weighted)		64		dB(A)
Total Harmonic Distortion	THD	94dB SPL @1KHz		0.15		%
Acoustic Overload Point	AOP	10% THD @ 1 kHz		128		dB SPL
Power Supply Rejection Ratio	PSRR	200mVpp sinewave @ 1kHz, VDD = 2.0V		75		dB
Power Supply Rejection	PSR	100 mVpp square wave @ 217 Hz, VDD = 2.0V, A-weighted		-105		dBV(A)
Phase Response	PR	20~10KHz@94dB	-5		5	deg
Output Impedance	Z _{out}	@1KHz			300	Ω

4. Frequency Response Curve

Frequency Response (0dB=1V/Pa)

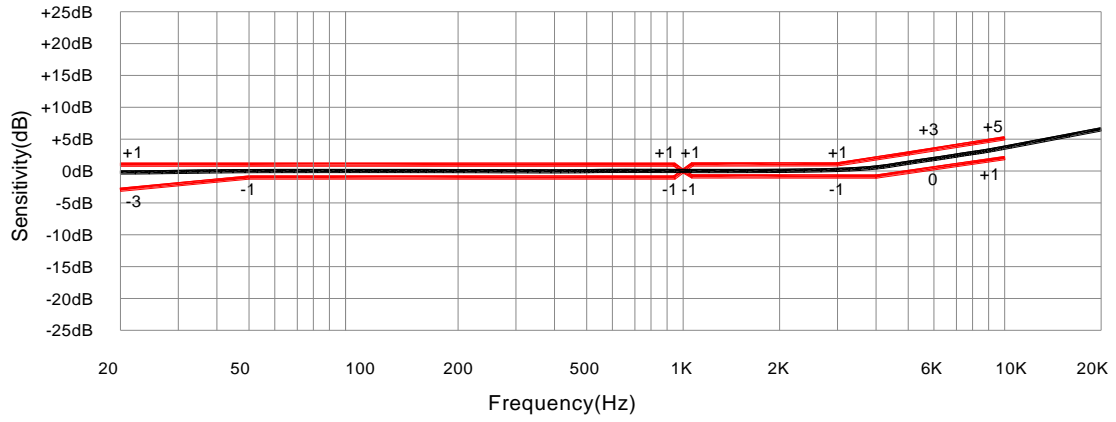

Phase

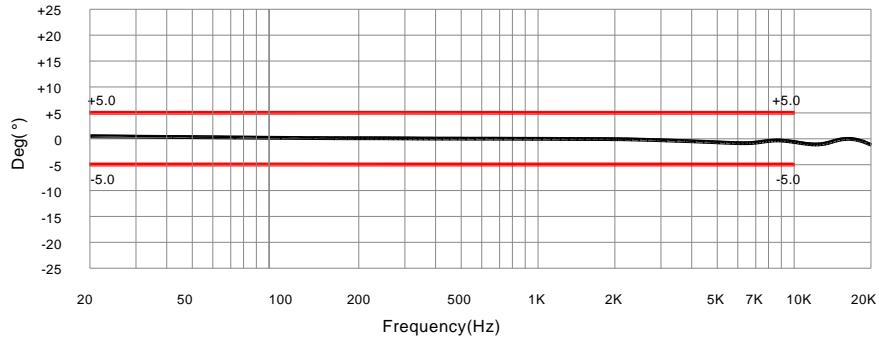

5. Test Setup Drawing

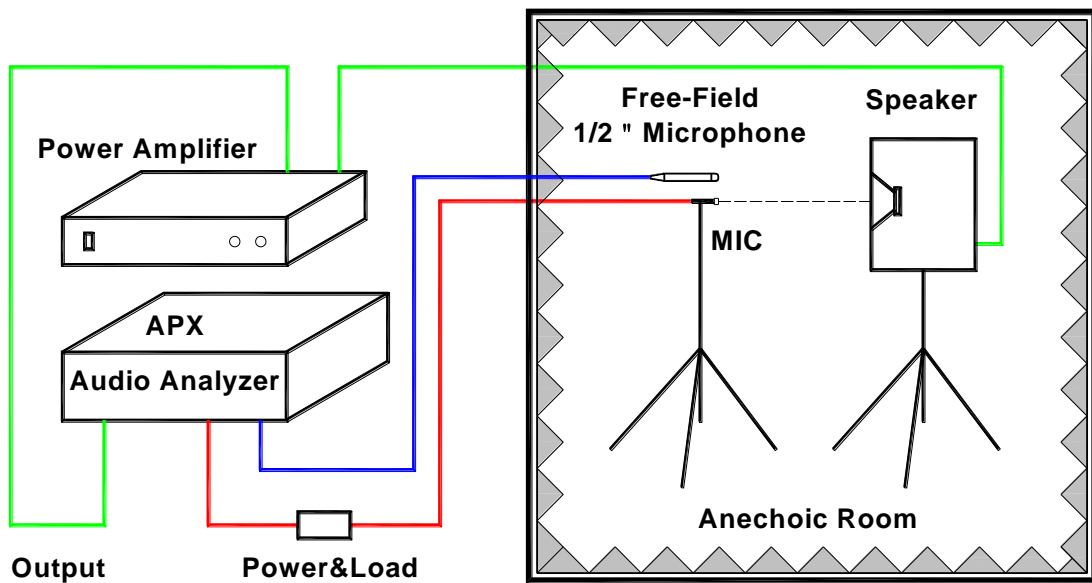

6. Mechanical Specifications

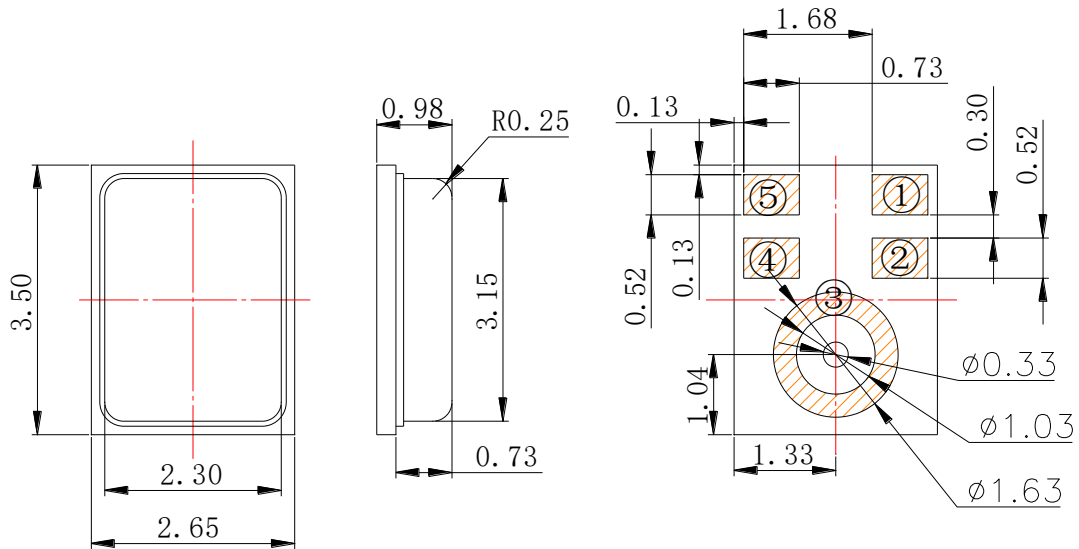

Item	Dimension	Tolerance	Units
Length(L)	3.50	± 0.10	mm
Width(W)	2.65	± 0.10	mm
Height(H)	0.98	± 0.10	mm
Acoustic port(AP)	$\phi 0.33$	± 0.10	mm

Pin Output	
Pin#	Function
1	Output
2	GND
3	GND
4	GND
5	V _{DD}

Note:

All dimensions are in millimeter(mm).

Tolerance: +/-0.1mm unless otherwise specified.

7. Recommended Interface Circuit

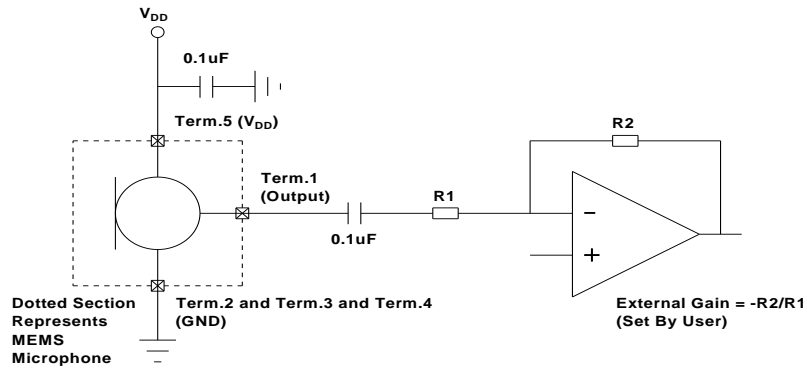

8. Vacuum nozzle pickup location

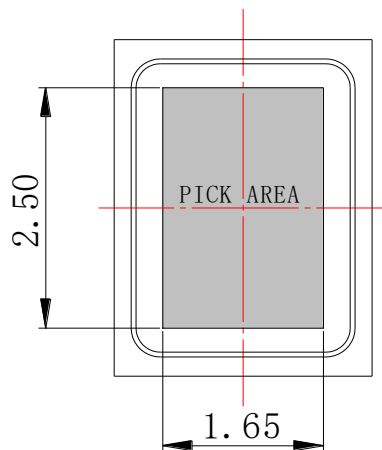

9. Example solder stencil pattern

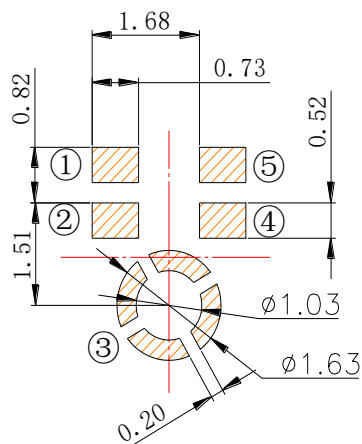

10. Recommended Reflow Profile

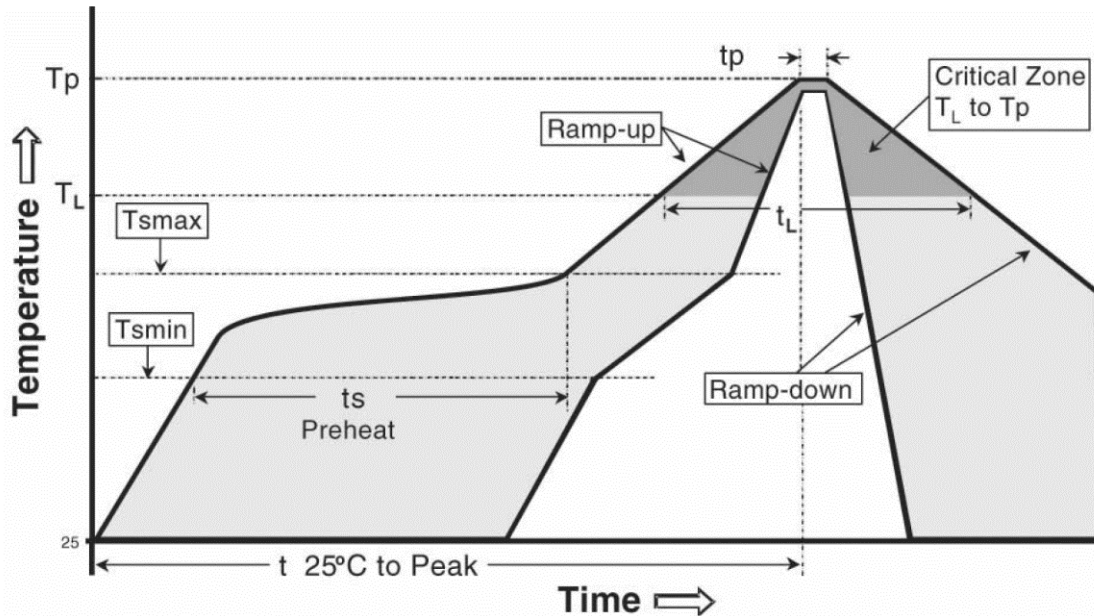

Profile Feature	Pb-Free
Average Ramp-up rate (T_{smax} to T_P)	3°C/second max.
Preheat Temperature Min (T_{smin}) Temperature Max (T_{smax}) Time (T_{smin} to T_{smax}) (t_s)	150°C 200°C 60-180 seconds
Time maintained above: Temperature (T_L) Time (t_L)	217°C 60-150 seconds
Peak Temperature (T_P)	260°C
Time within 5°C of actual Peak Temperature (t_p)	20-40 seconds
Ramp-down rate(T_P to T_{smax})	6°C/second max
Time 25°C to Peak Temperature	8 minutes max

Notes:

1. Pulling vacuum over acoustical hole of the microphone is not allowed, because the device can be damaged by vacuum.
2. Wash the board after reflow process is not allowed, because board washing and cleaning agents can damage the device. Device should not be exposed to ultrasonic processing or cleaning.
3. Recommended number of reflow is no more than 3 times.

11.3. The Content of Box(13" reel)

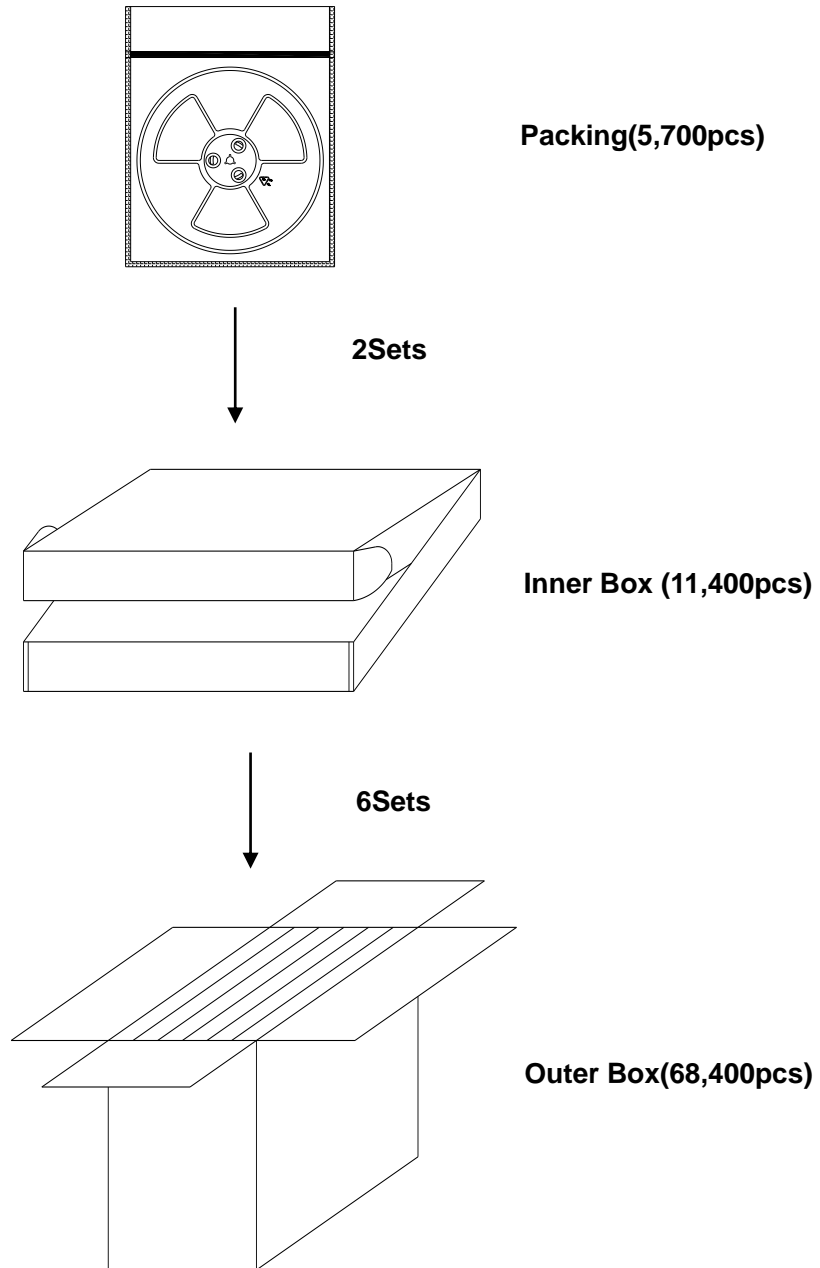

Qty/ Reel	Qty/ One Inner Box	Qty/ Outer Box (Six Inner Box)
5,700 pcs	11,400 pcs	68,400 pcs
Φ 330mm	355 × 340 × 45mm	365 × 290 × 370mm

12. Reliability Specifications

Test Item	Detail
Thermal Shock	100 cycles of air-air thermal shock from -40°C to +105°C with 15 minute soaks.
High Temperature Storage	+105°C environment for 500 hours.
Low Temperature Storage	-40°C environment for 500 hours.
High Temperature Test	+105°C environment while under bias for 500 hours.
Low Temperature Test	-40°C environment while under bias for 500 hours.
Humidity Test	+85°C/85% R.H. environment while under bias for 500 hours.
Vibration Test	16 minutes in each X, Y, Z axis from 20 to 2,000 Hz with peak acceleration of 20G.
Drop Test	1.5-meter height onto a concrete surface each time at three directions in state of packaging.
Reflow Test	5 reflow cycles with peak temperature of +260°C.
ESD Test	Under C=150pF, R=330ohm. Tested to ±8KV contact to the case and tested to ±2kV contact to I/O terminals. 10 times. Grounding.

Note: The microphone sensitivity after stress must deviate by no more than ±3dB from the initial value.

